

Application for Cemetery Burial Warrant

Application Date _____

Deceased Details

Surname _____ **First Names** _____
Gender Male Female Other **Age** _____
Place of Death _____
Date of Death _____ **Place of Birth** _____
Last Occupation _____ **Religion** _____
Last Address _____
Next of Kin _____ **Relationship** _____
Address _____

Funeral Director OR Payer

Full Name _____ **Phone** _____
Email _____
Postal Address _____

I confirm that the details of the deceased listed above are correct and is the person being interred.



Date _____ **Signed** _____

Burial Details

Cemetery _____ **Plot Number** _____
Date of Burial ____/____/20____ **Time of Arrival at Cemetery** _____
Day of Burial _____

Body Burials

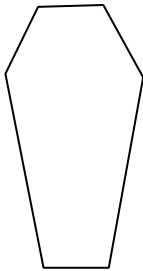
Please indicate Casket Shape

Standard Size
2100mm Length x 770mm Width

If other than above, please provide measurements

Max Length _____mm

Max Width _____mm (including handles)

Max Height _____mm

Burial Type

Body Ash Scatter

Plot Type

Standard RSA Family
 Child Infant
 Reserved Re-Open
 Single Depth Extra Depth

Options

Mats
 Lowering Device (*Funeral Directors own*)
 Sticks & Straps
 Backfilling by contractor
 Backfilling by family

Burial Warrant is hereby granted by the
Cemeteries Manager

Warrant No. _____ Date: ____/____/20____

Please Note: Burials and/or Scatterings cannot take place until the Burial Warrant has been granted.

Application for Cemetery Burial Warrant

Terms and Conditions

When purchasing a plot, you are in fact purchasing exclusive right of interment and not the land itself, this remains the property of Kaipara District Council.

Exclusive right of interment expires after 60 years if the plot has not had an interment take place. If a burial/interment has not taken place in that plot within that time, Kaipara District Council reserves the right to revoke the Exclusive Right of Interment in accordance with the Burials and Cremation Act 1964.

All fees must be paid in full before a burial can take place. Council does not offer a credit facility to private individuals. Payment can be made in person at any Council Service Centre or by internet banking.

Only Council or its representative is authorised to dig a grave or ash plot.

Adornments, including all wreaths and floral tributes may be placed on a plot for up to 30 days following an interment. After this time, all adornments will be relocated to the concrete beam or transferred to the Tribute Pick up Area and marked with the name of the interred person/s. A note will be placed at the plot advising family of this. Any adornments added after this time must be confined to approved receptacles, or the concrete berm.

Please acknowledge by signing below that you accept the terms and conditions are set out on this application.

Signed on behalf of the Family _____

Name _____

Date _____