

# PSS Eco 1-60

## Health and Safety Features

Access to wet well—Eliminates the risk of accidental ingress of personnel to wet well.

Pump and Level Controls in dry-well—No pump, slings, cables or controls immersed in sewage

No access to wet well when pump chamber cover is removed

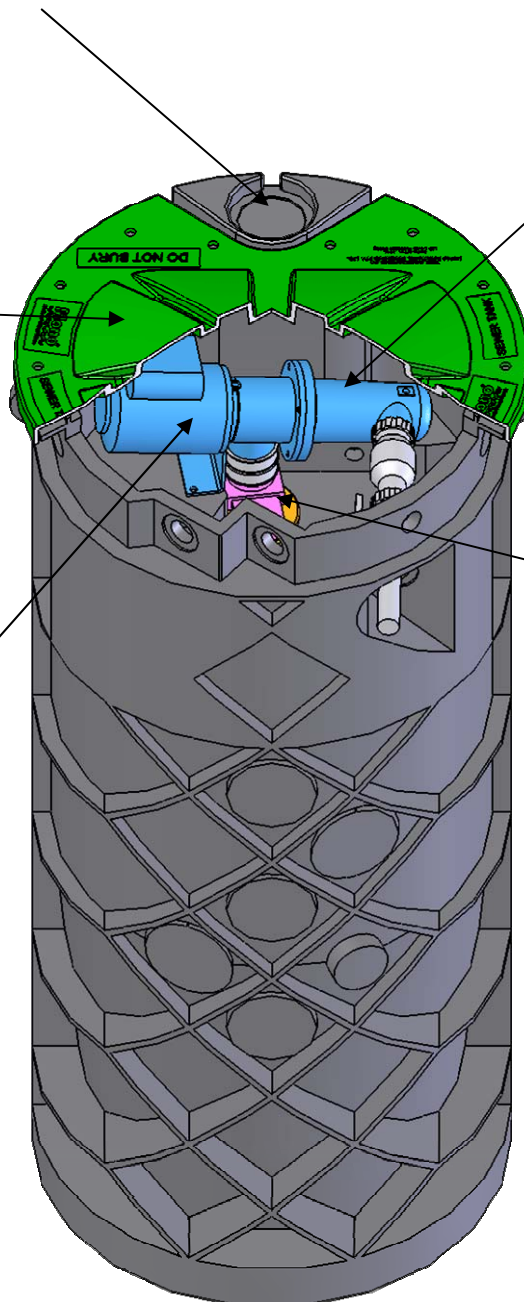

Knife gate valve— Isolates wet well preventing spillage and odours when removing pump

Dry Well Pump weight 32kg—No external contamination. Only requires a lift of 0.5metres

Smart current sensing pump controls (adjustable) eliminate the risk associated with system over pressure— no delay associated with thermal fault protection

Completely assembled, tested and delivered as a unit—No further assembly required—eliminates the risk associated with installation of components